

CPN

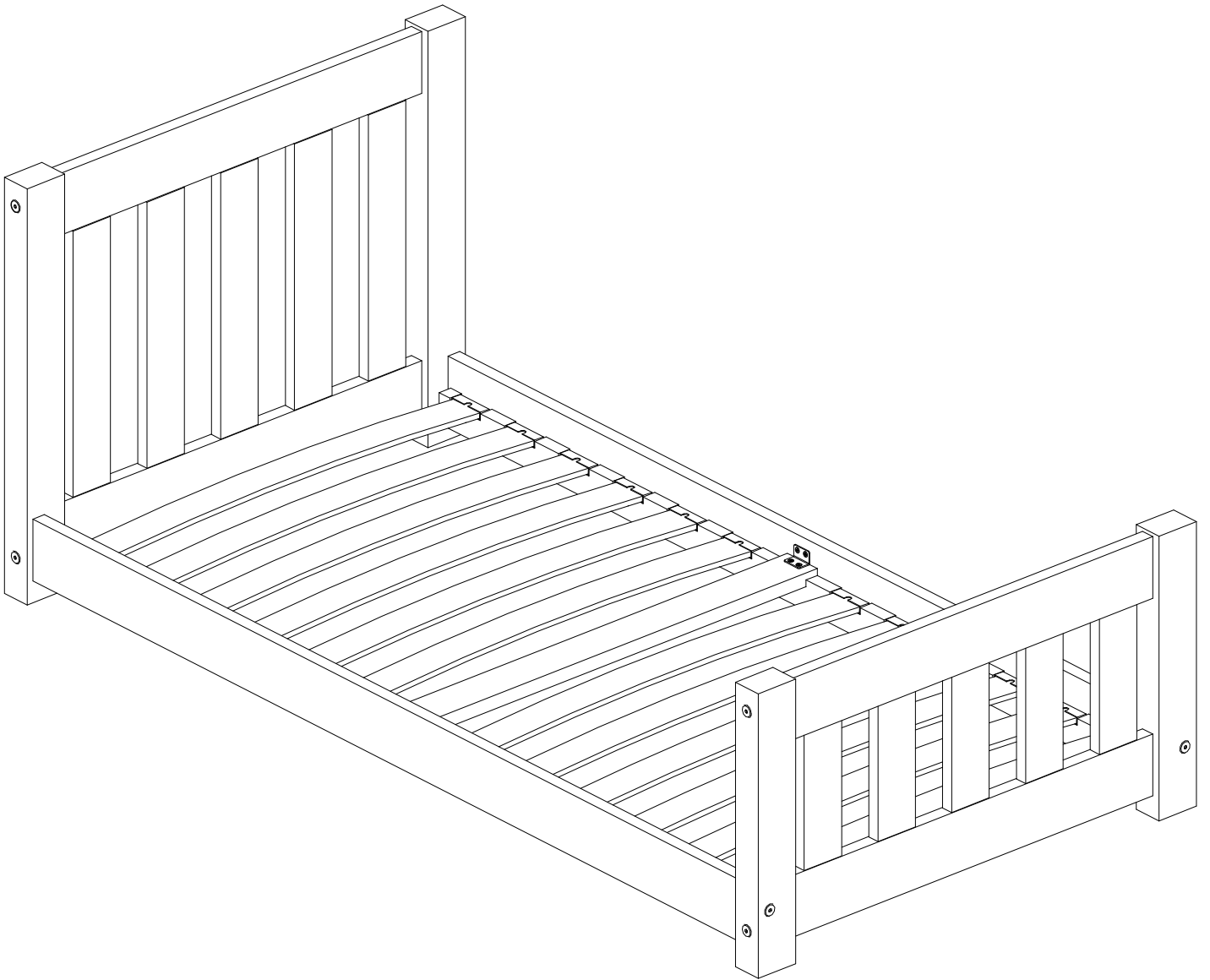

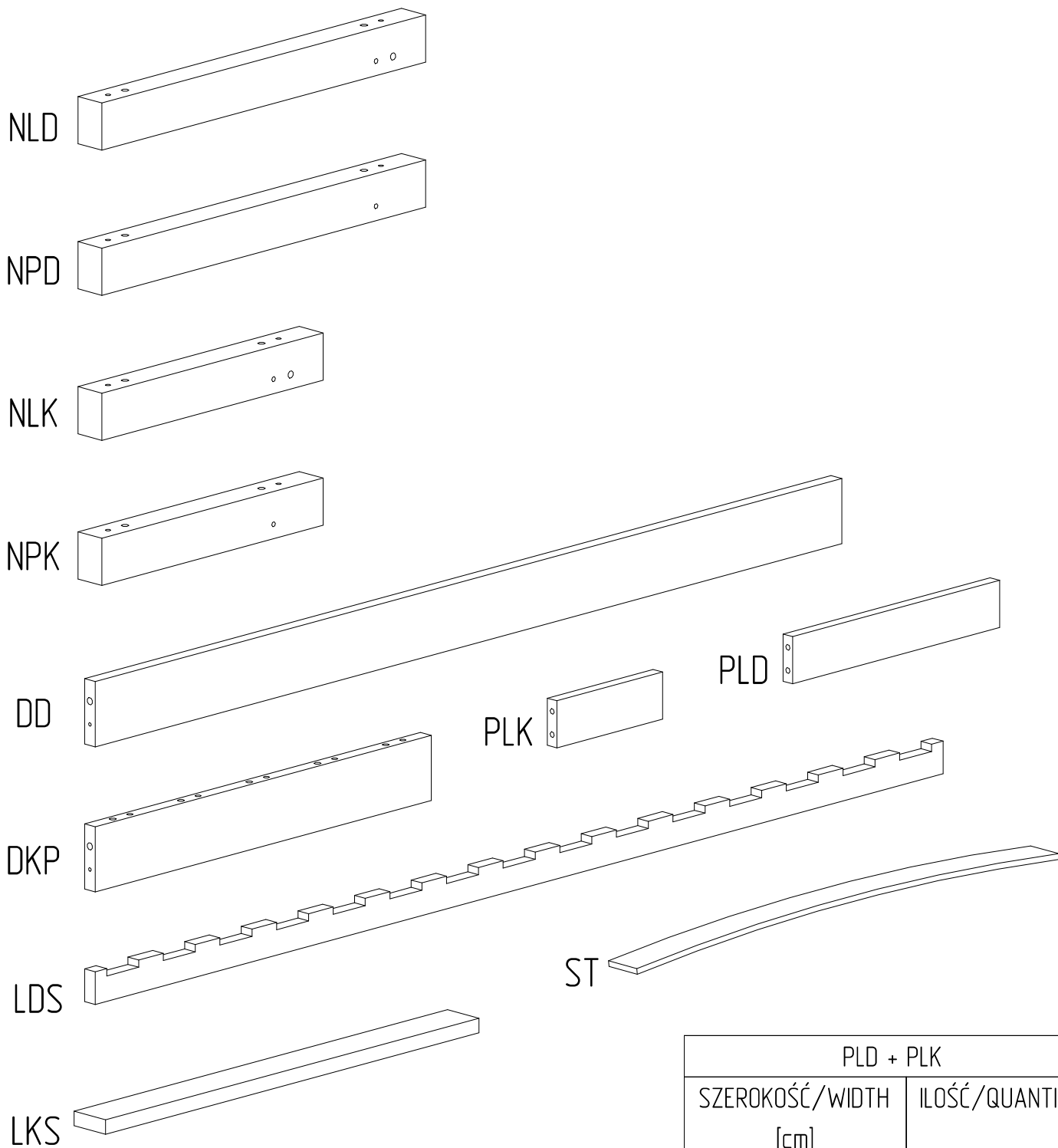

ST	
DŁUGOŚĆ/LENGTH [cm]	ILOŚĆ/QUANTITY
140	12
160	14
180	14
190	16
200	16

PLD + PLK	
SZEROKOŚĆ/WIDTH [cm]	ILOŚĆ/QUANTITY
700	10
800	10
900	12
100	14
120	18
135	20
140	20
160	24

CZĘŚĆ/PART	NLD	NPD	NLK	NPK	DD	DKP	LDS	LKS
ILOŚĆ/QUANTITY	1	1	1	1	2	4	2	1

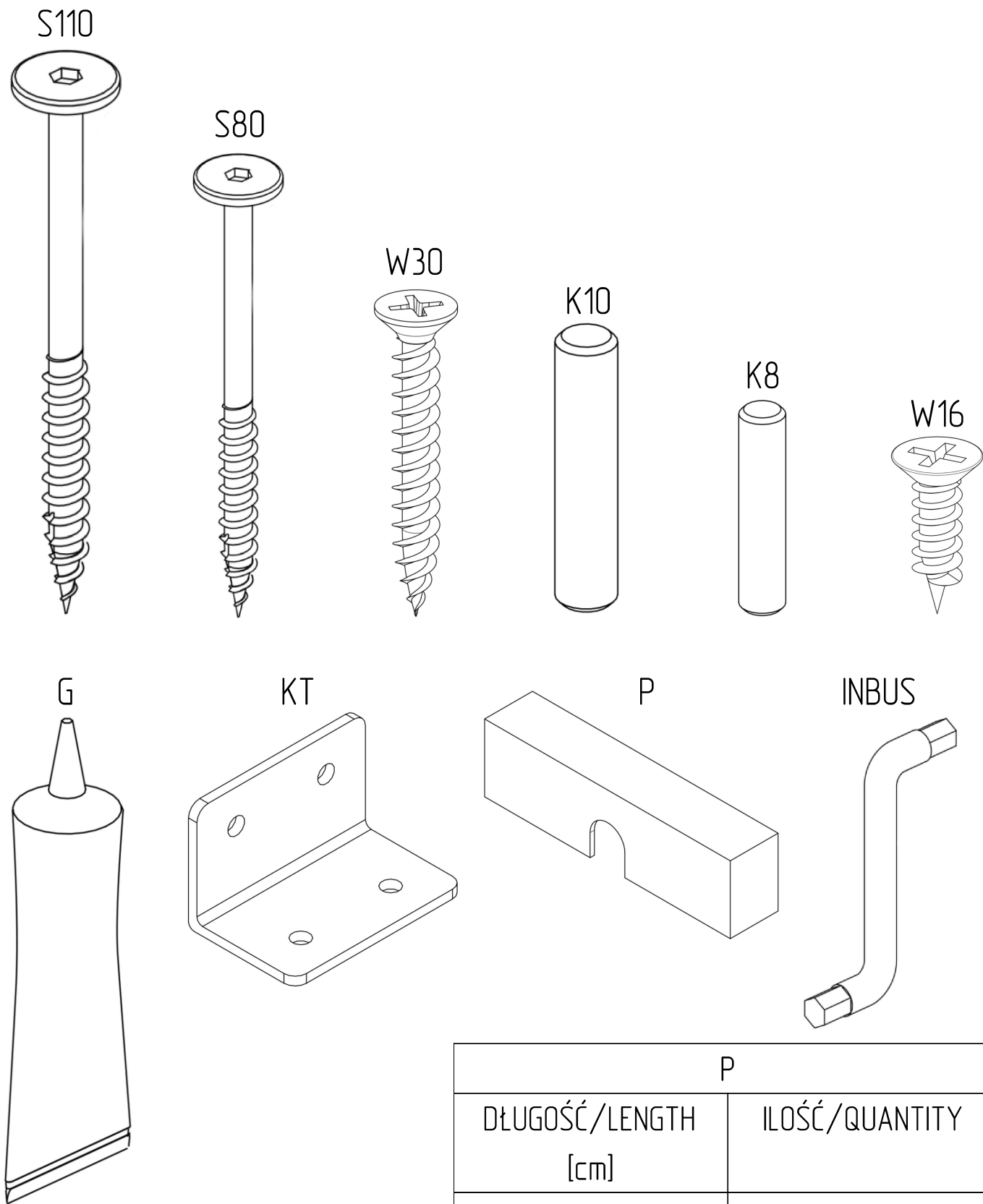

P	
DŁUGOŚĆ/LENGTH [cm]	ILOŚĆ/QUANTITY
140	24
160	28
180	28
190	32
200	32

ELEMENT/PART	S110	S80	W30	K10	W16	G	KT
ILOŚĆ/QUANTITY	8	4	12	12	8	3	2

ILOŚĆ/QUANTITY OF K8

SZEROKOŚĆ/WIDTH [cm]	ILOŚĆ/QUANTITY
70	20
80	20
90	48
100	56
120	72
135	80
140	80
160	96

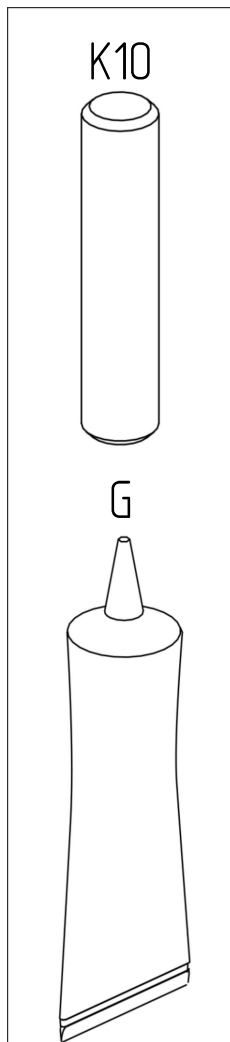
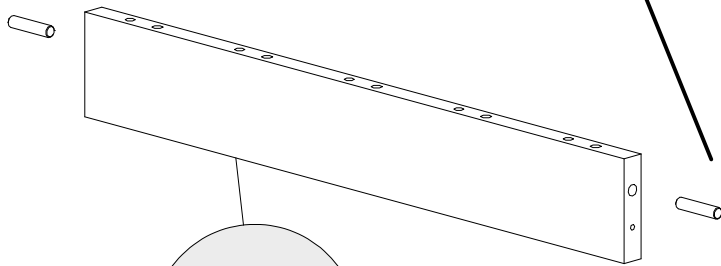
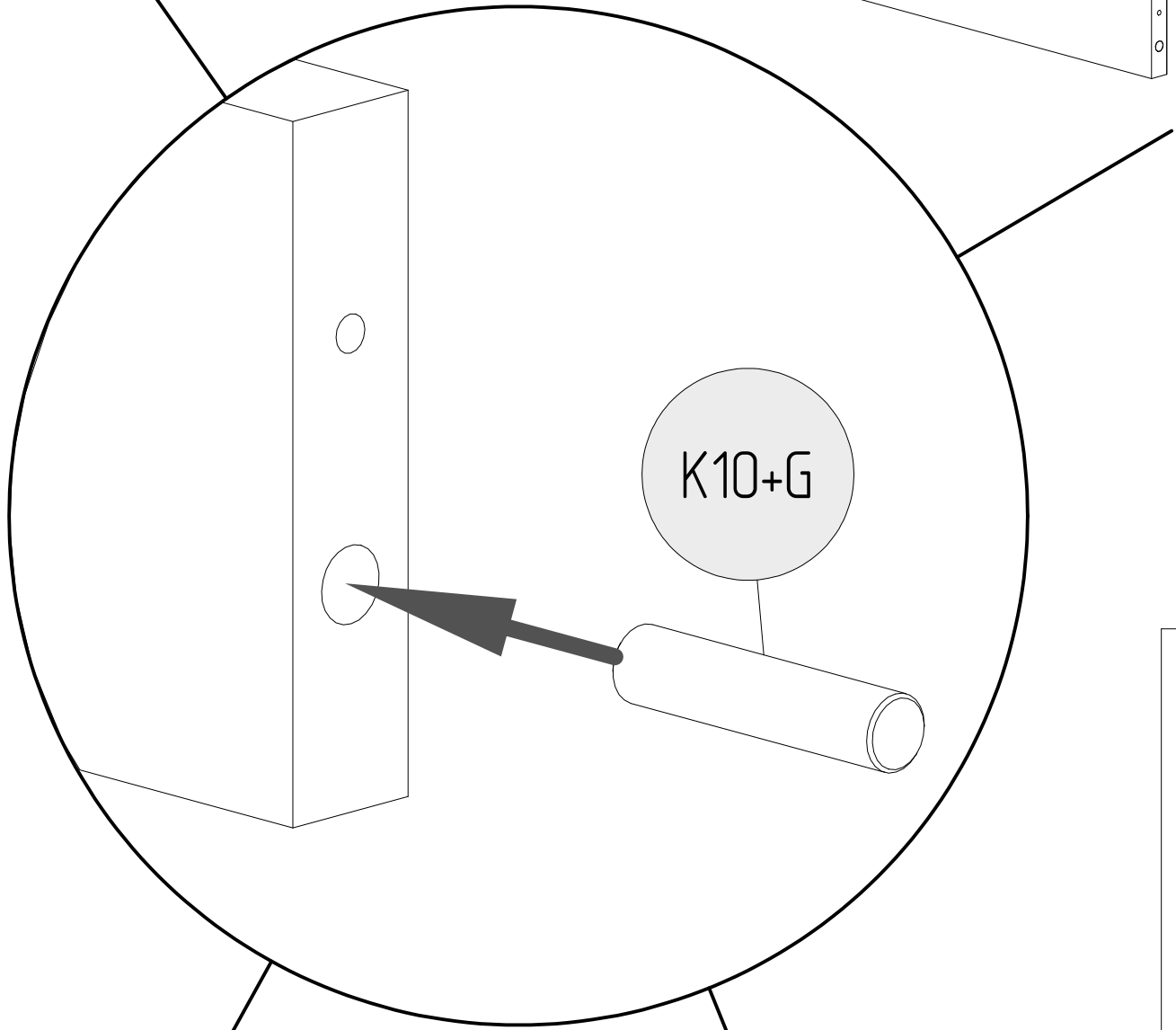
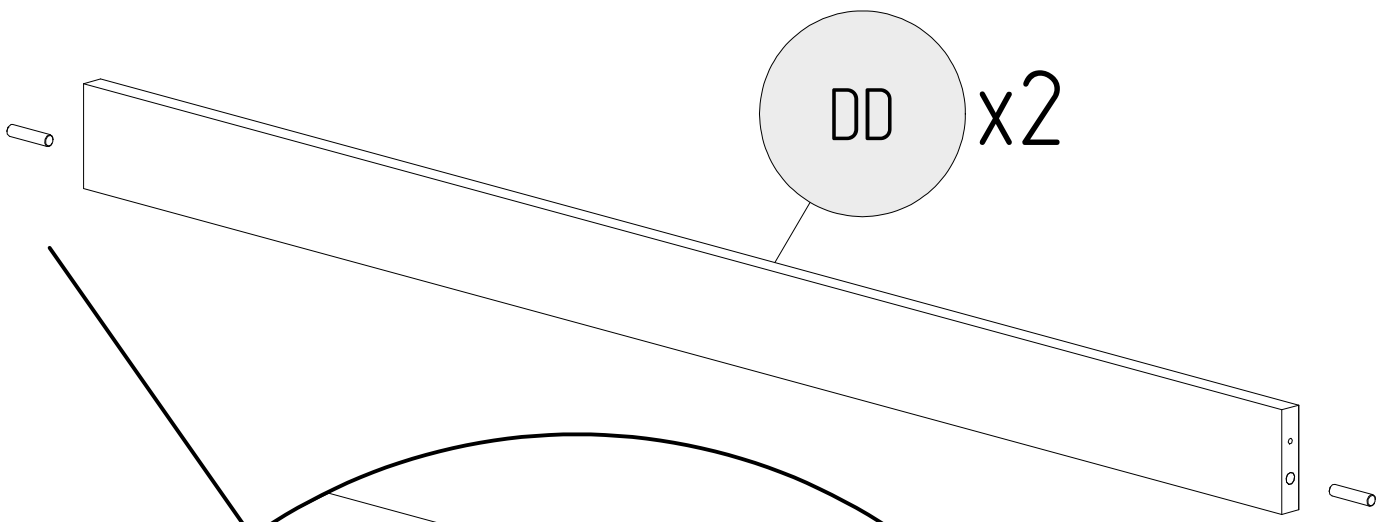

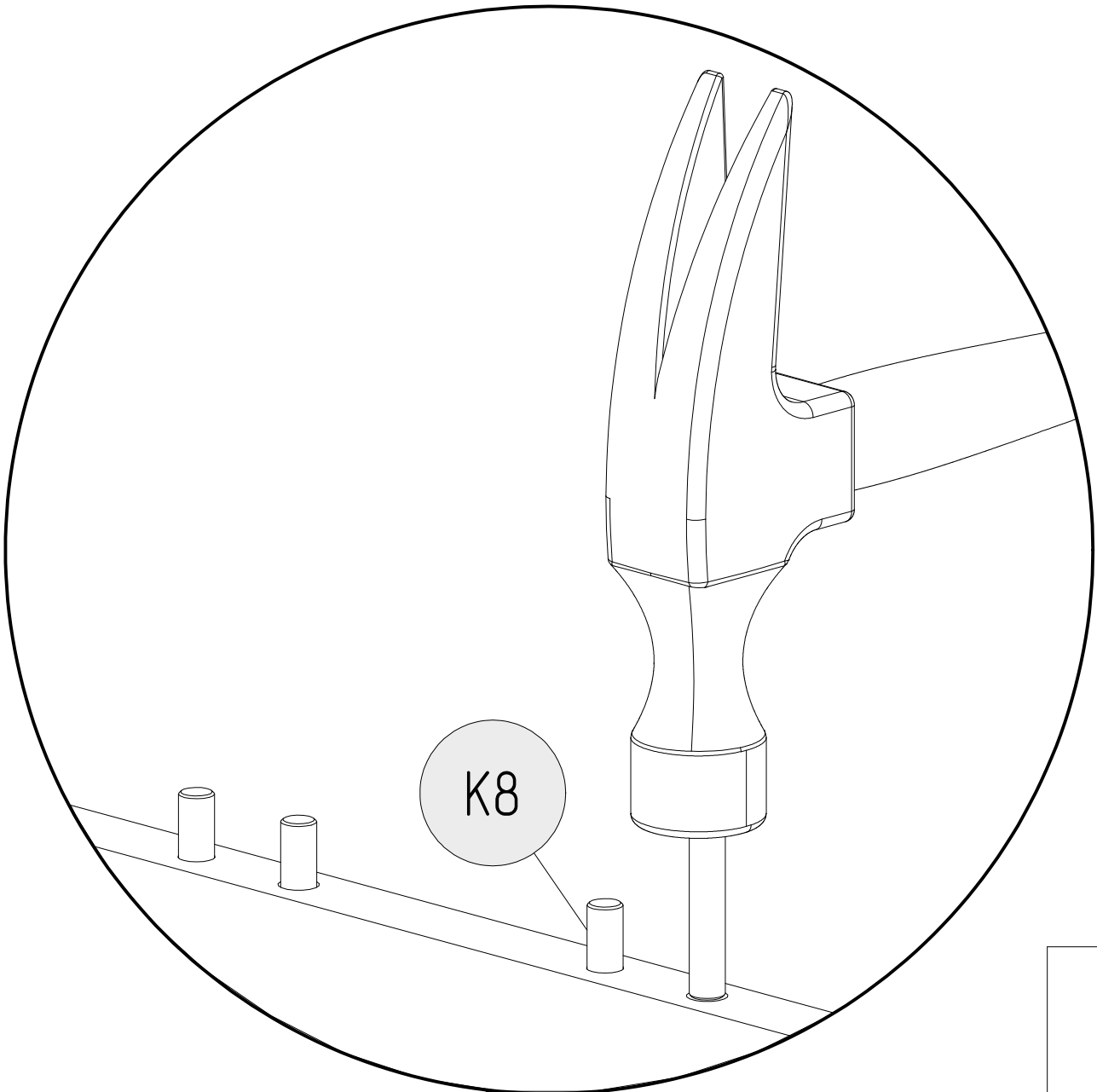

K8

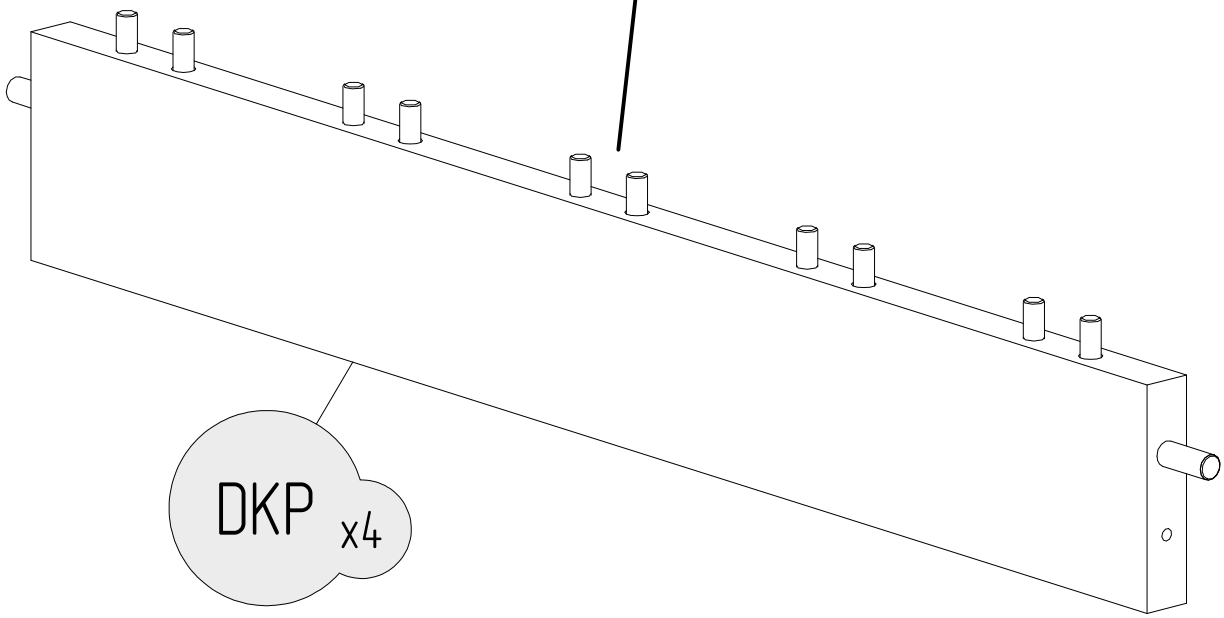

DKP x4

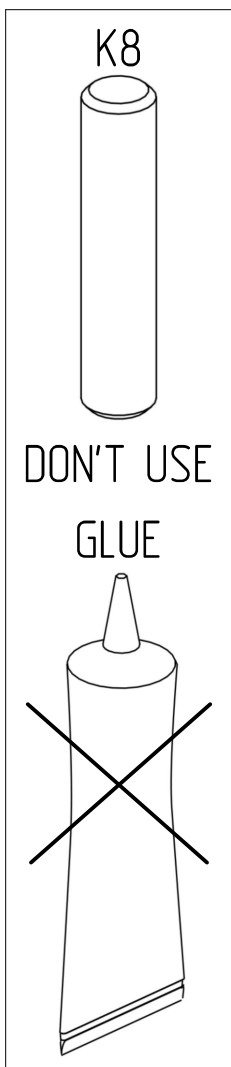

K8

DON'T USE
GLUE

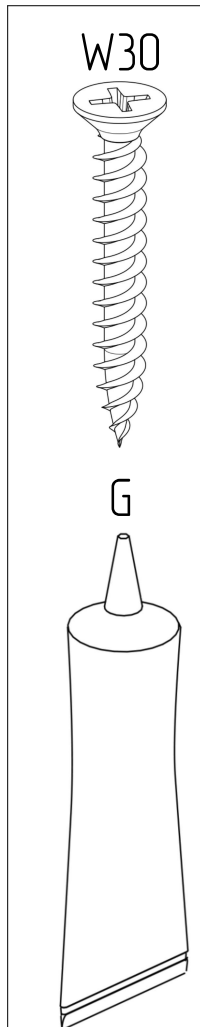
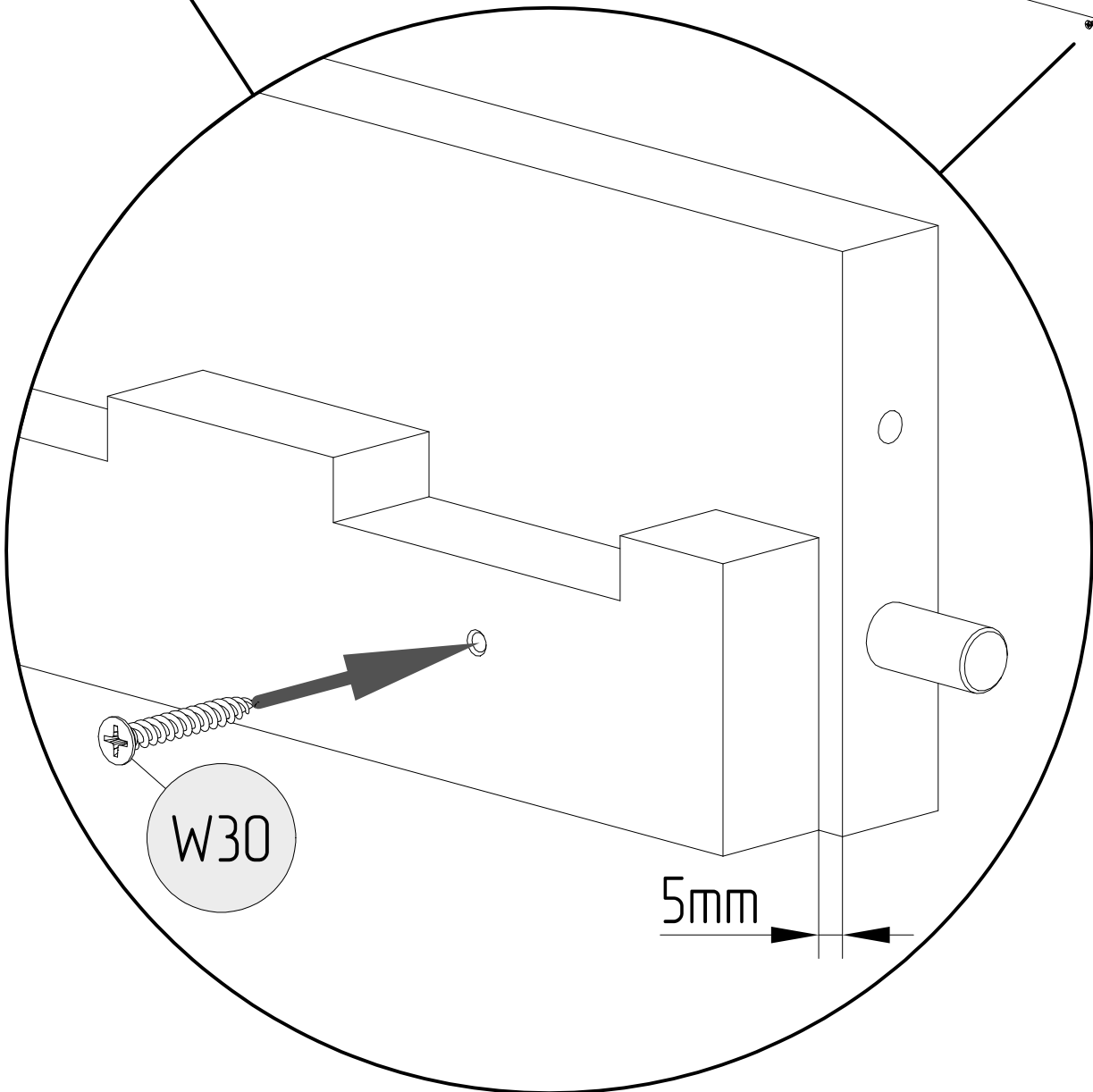
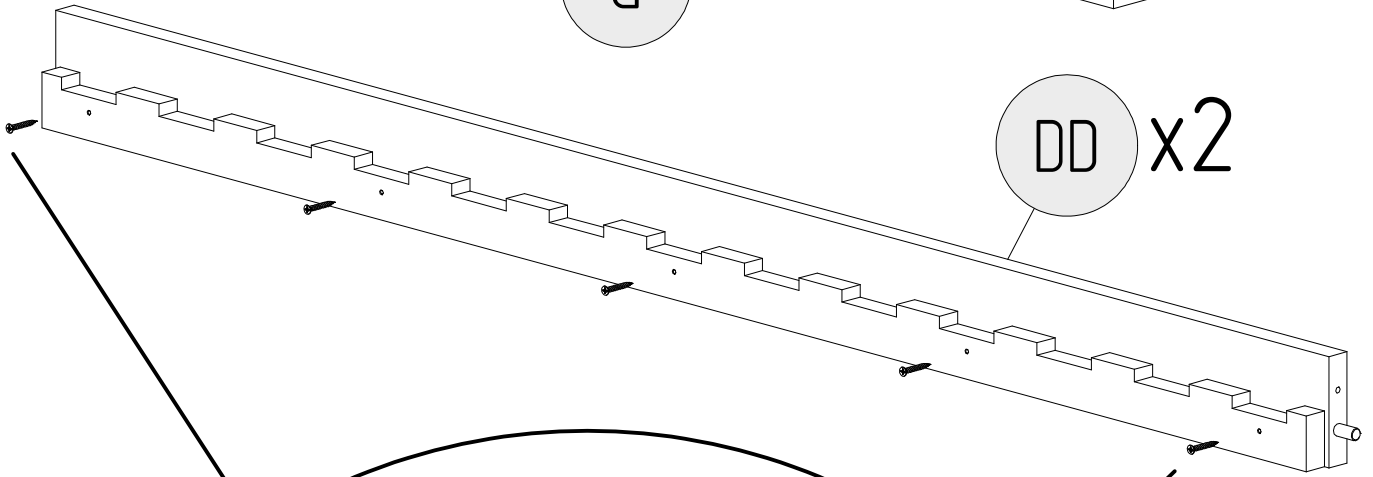
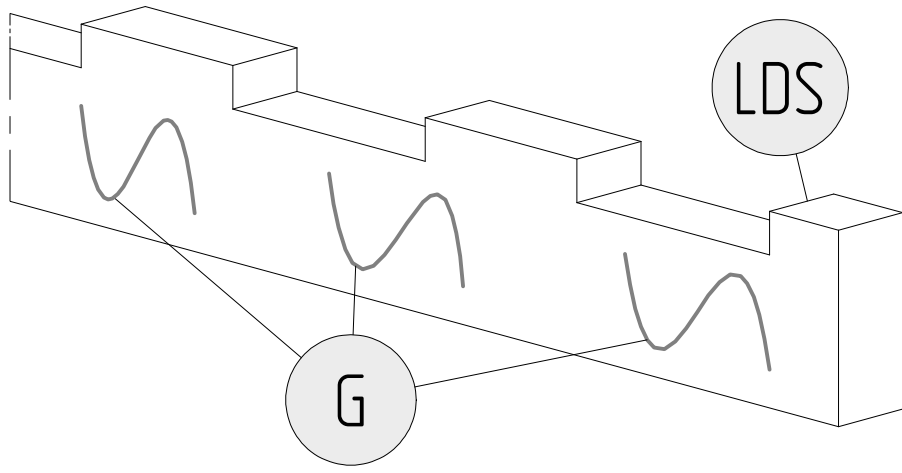

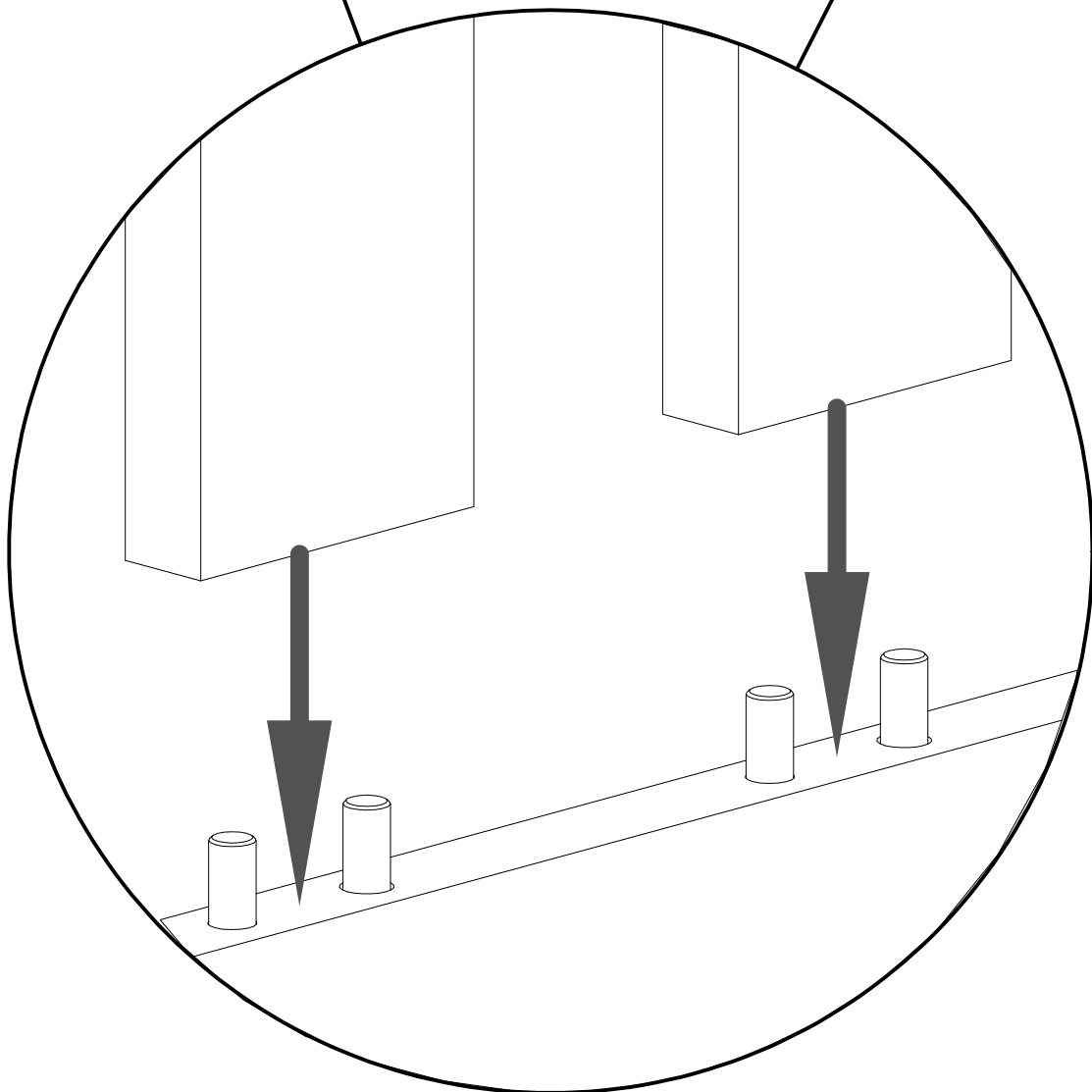
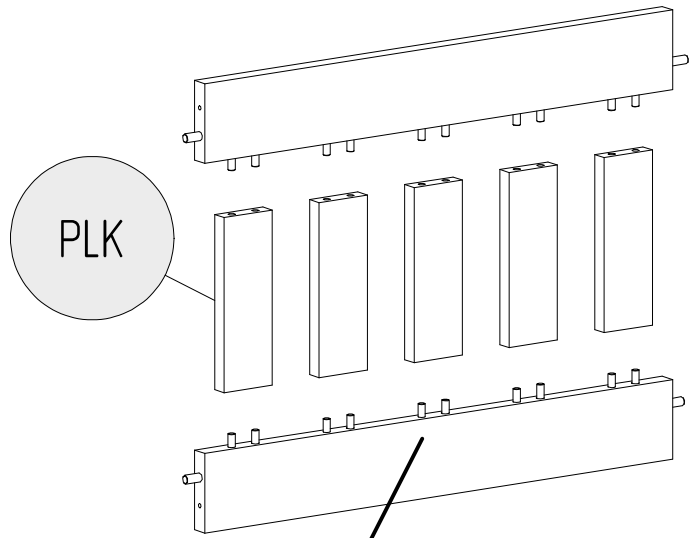
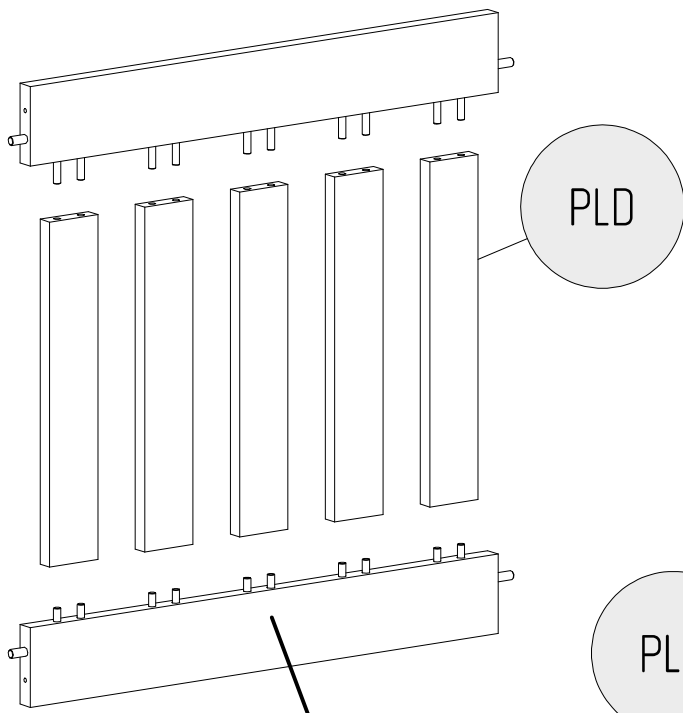

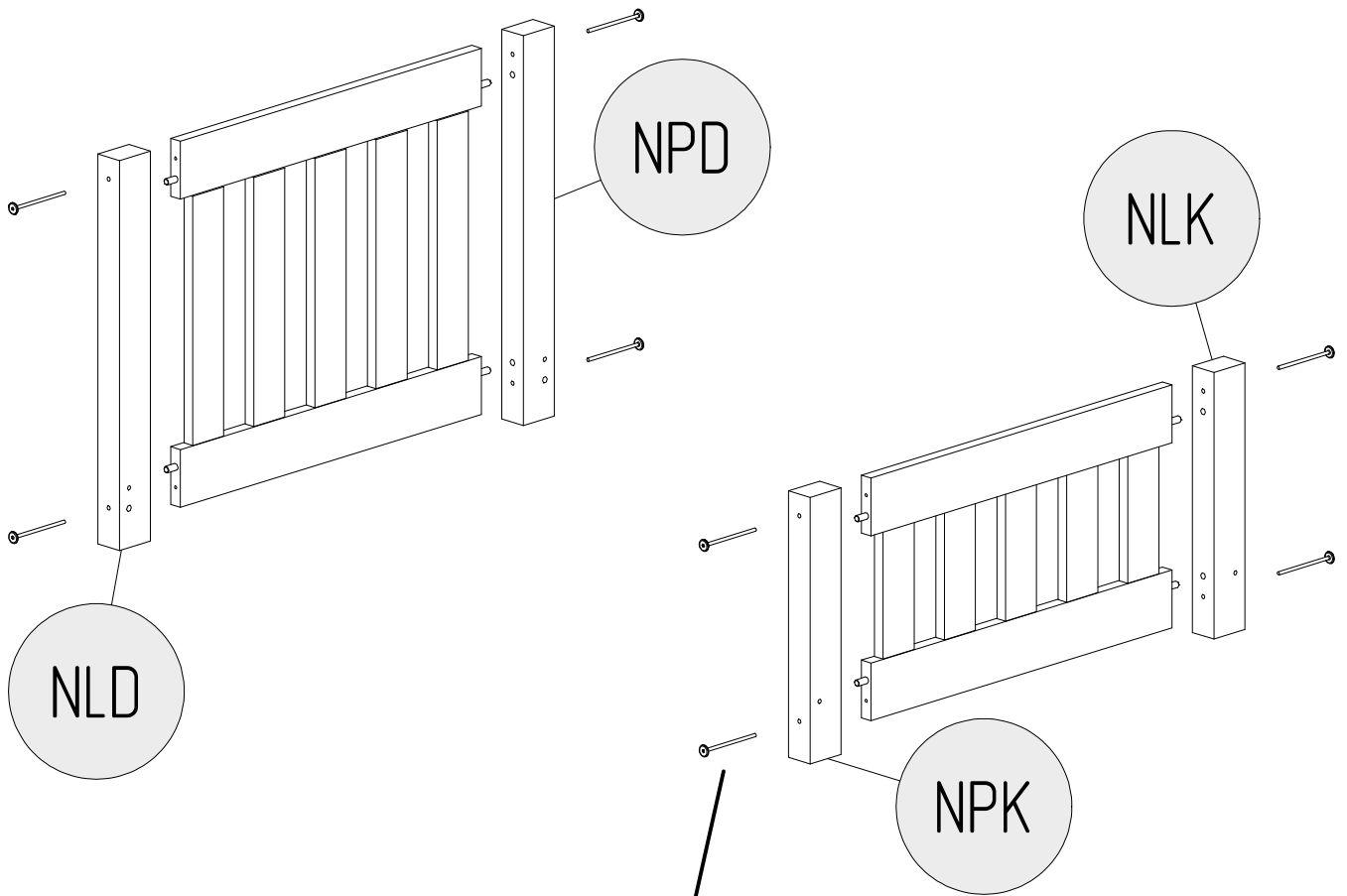

*czynność powtórzyć dla każdej nogi
*repeat the action to each bed leg

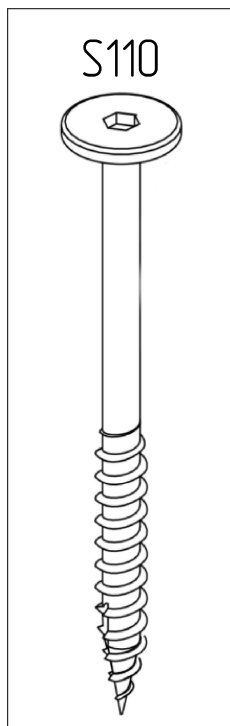
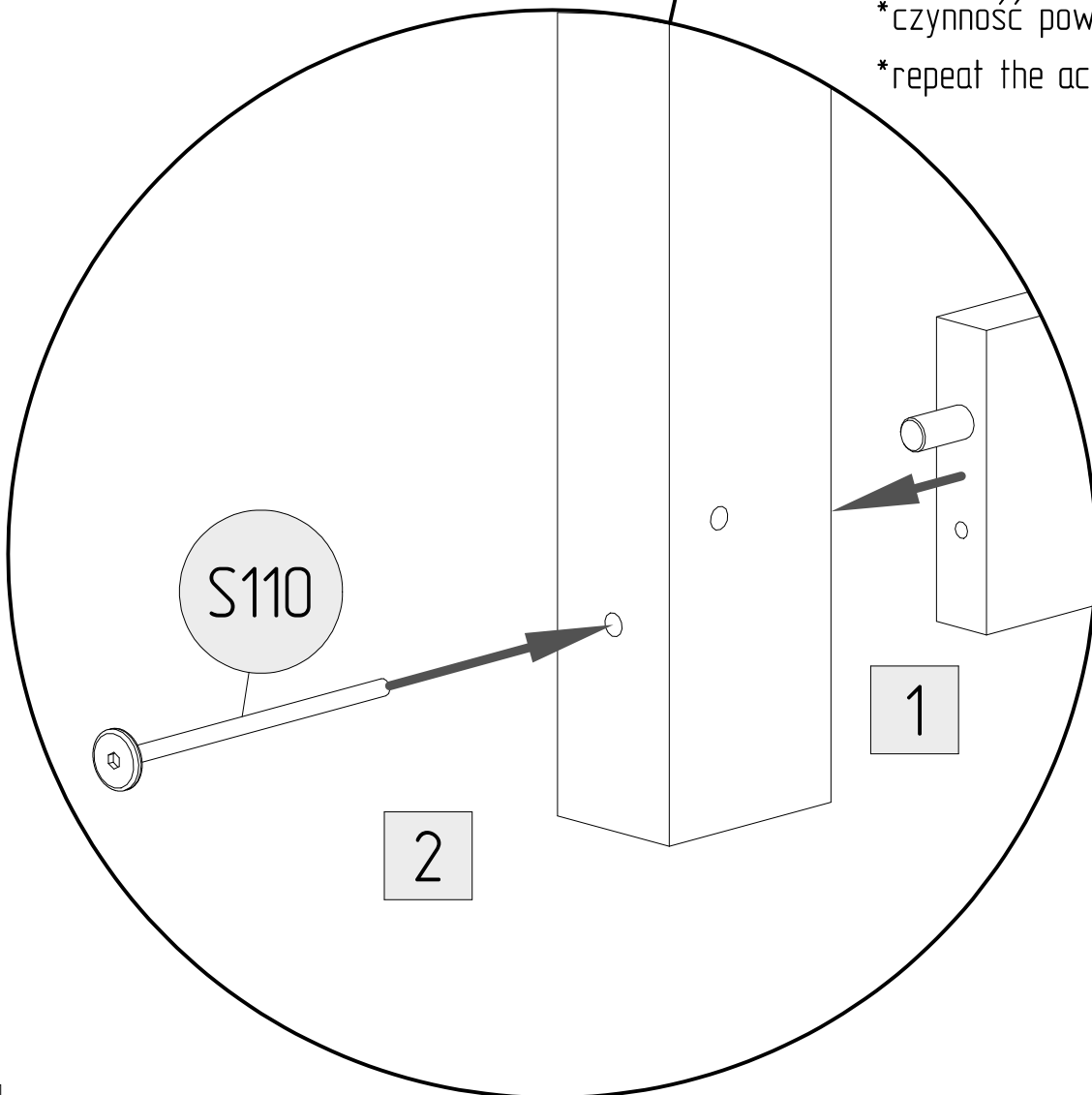

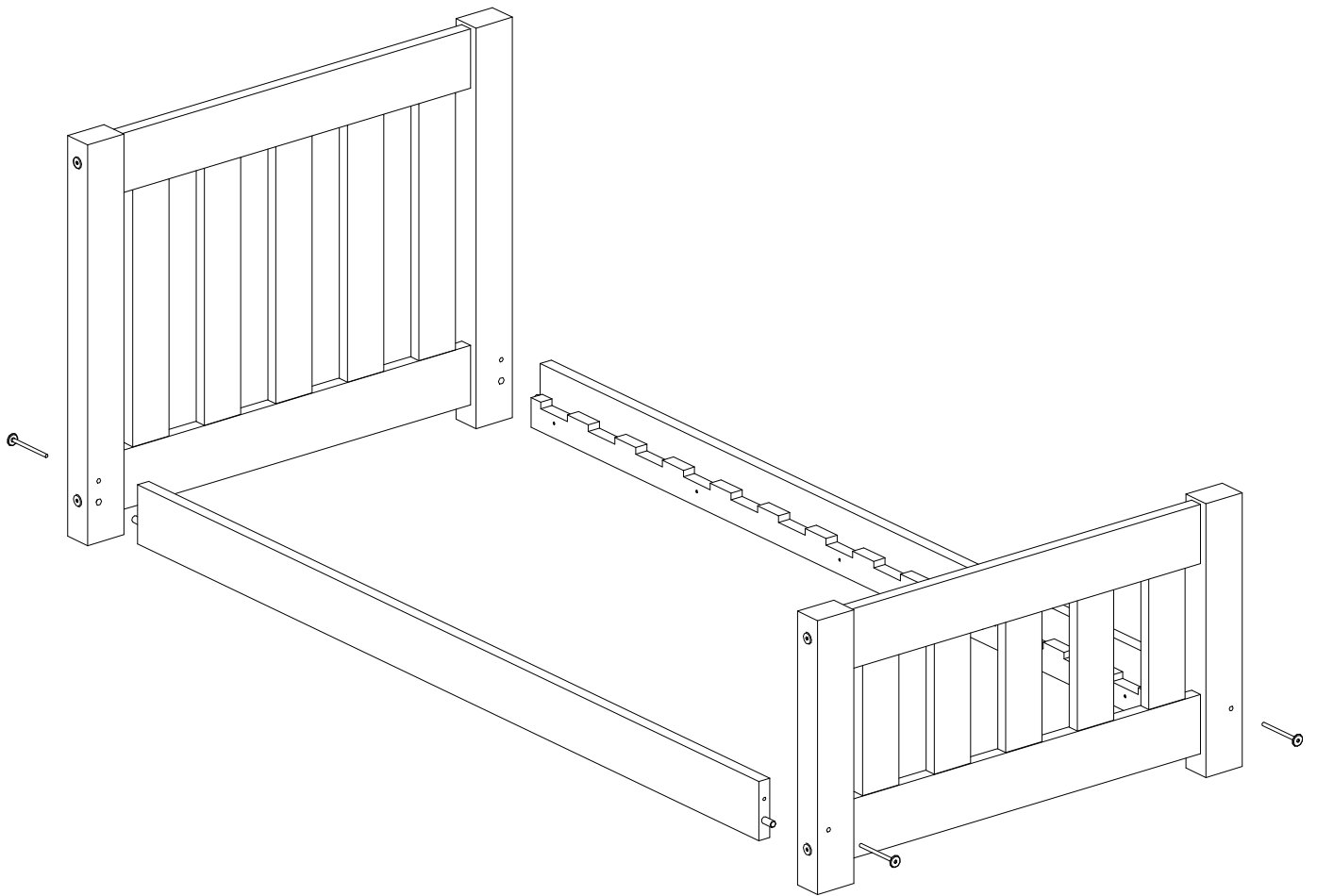

*czynność powtórzyć dla każdej nogi
*repeat the action to each bed leg

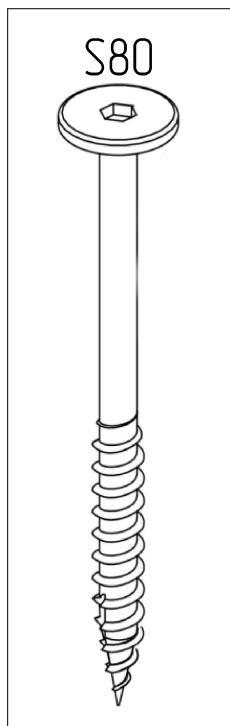
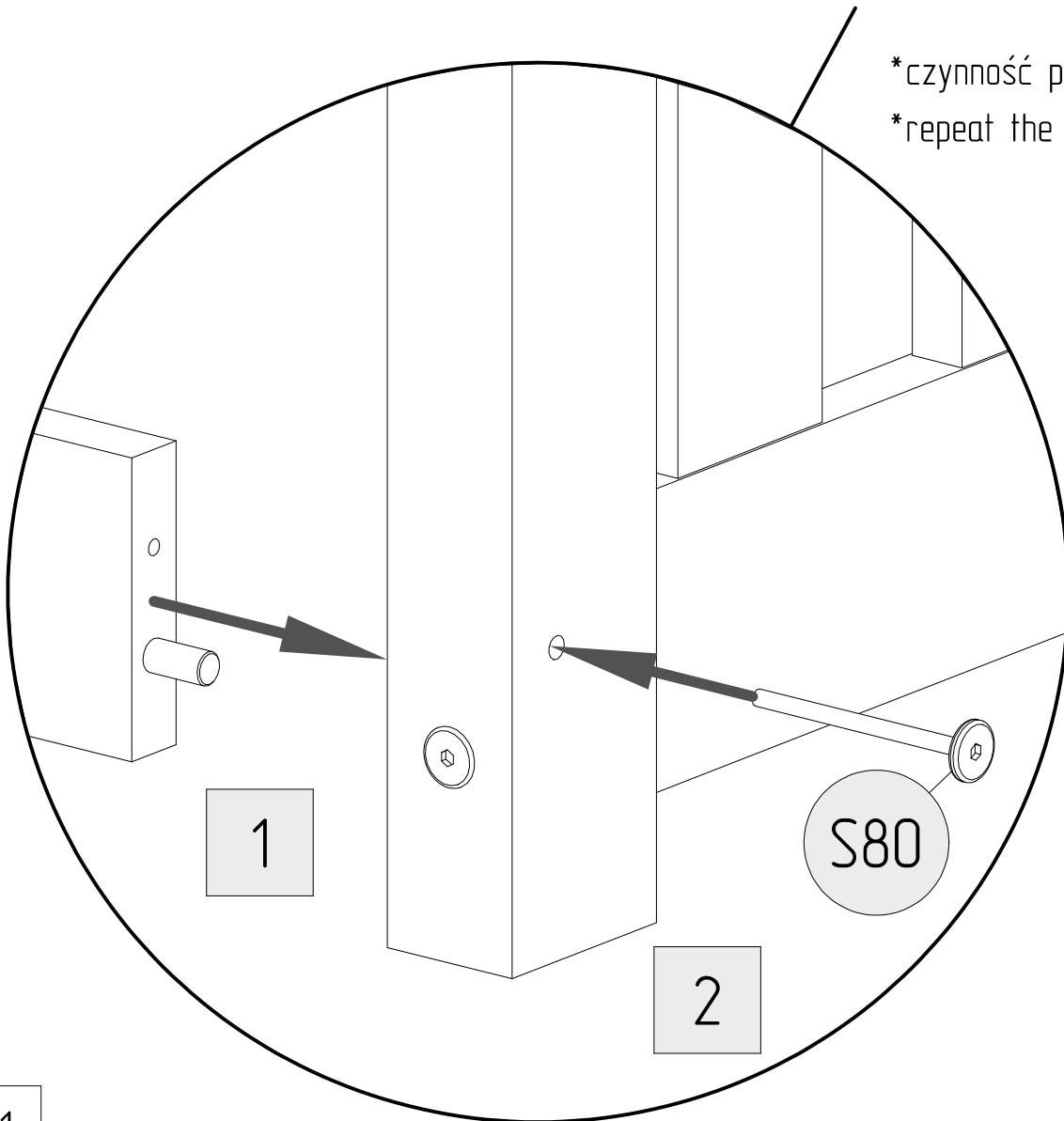

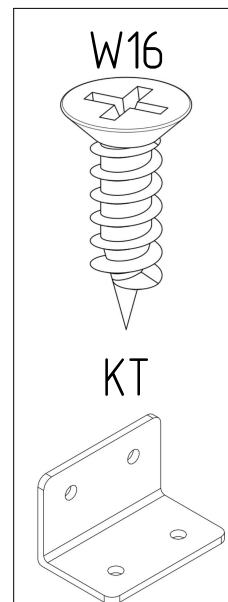
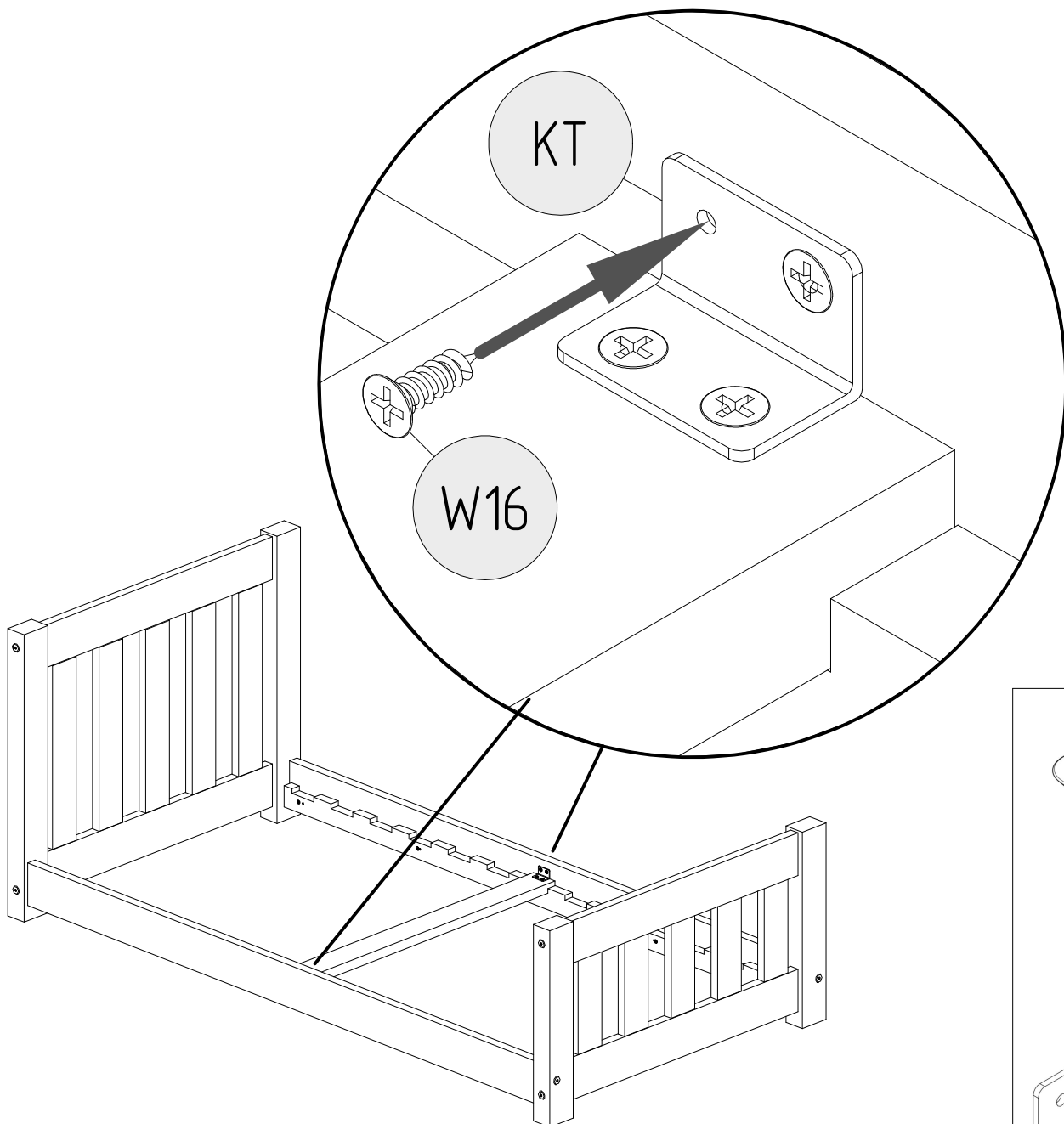
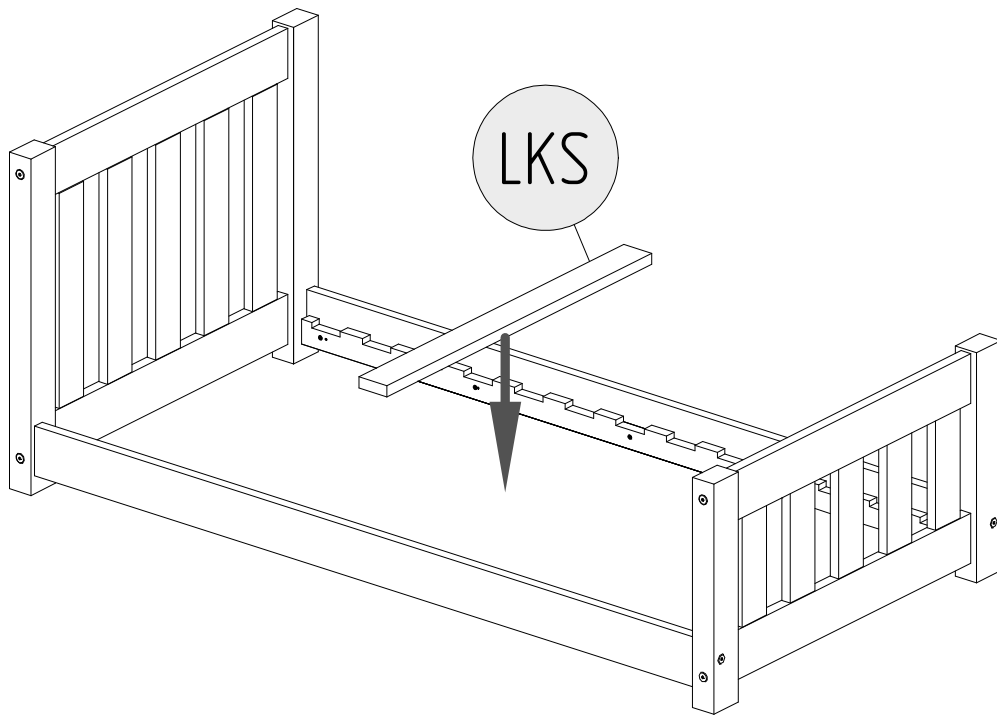

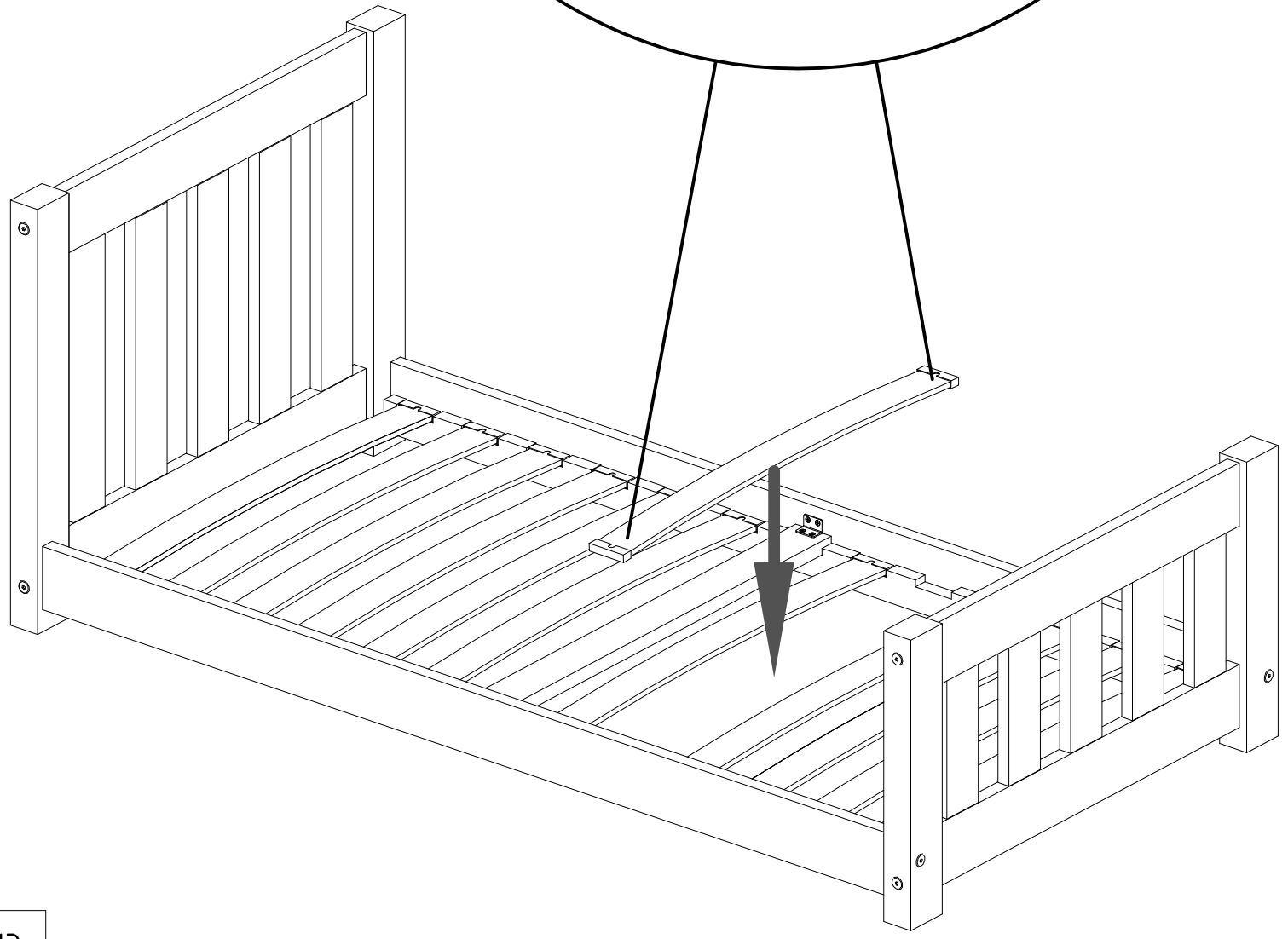
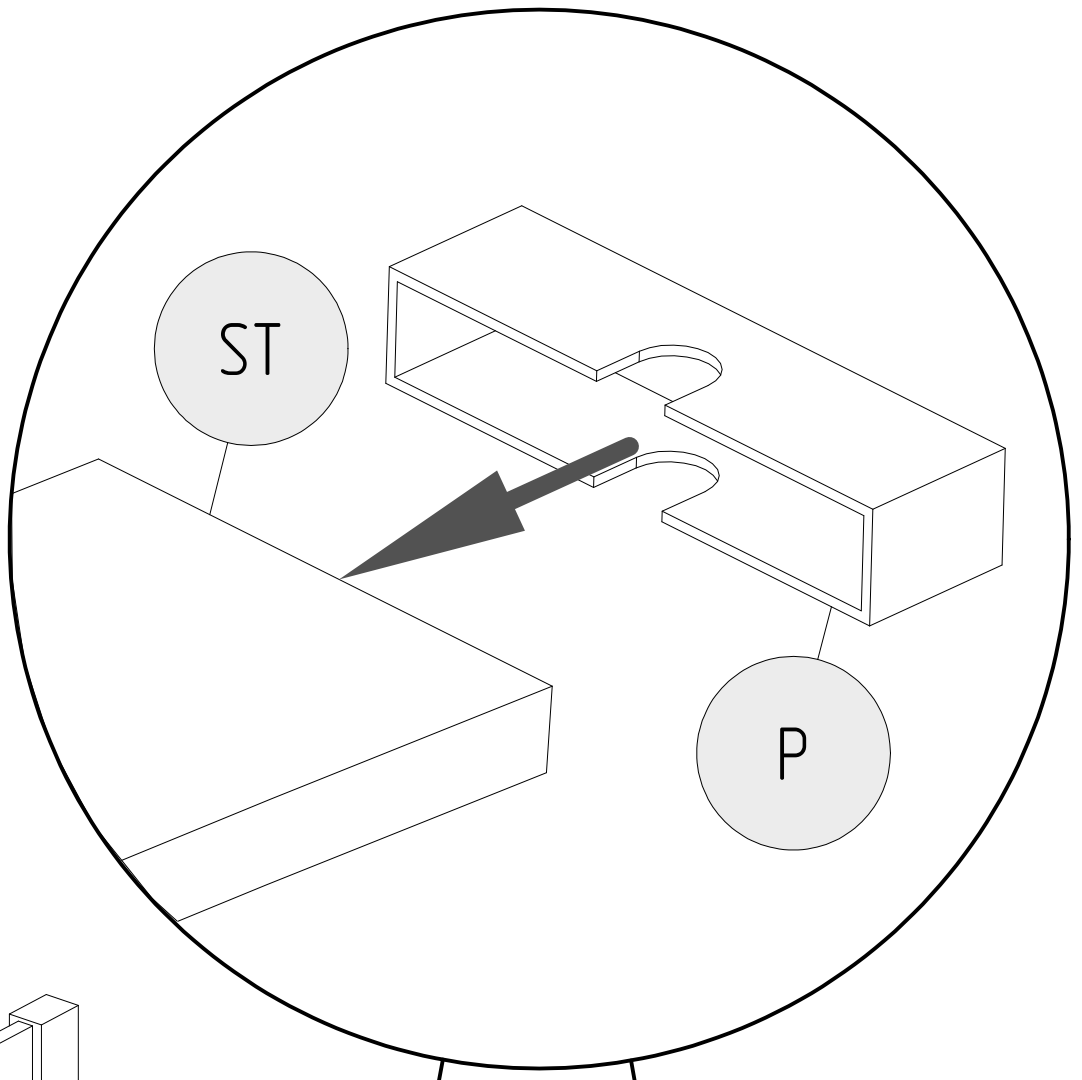
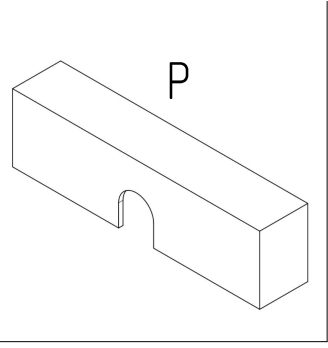

UWAGA / WARNING

- Używać tylko materacy o grubości 8-16 cm
- Nie skakać na łóżku
- Nie wieszać się na elementach konstrukcyjnych
- Maksymalne obciążenie konstrukcji wynosi 100 kg

Części drewniane i plastikowe należy czyścić za pomocą suchej szmatki oraz zwykły, łagodnych środków do pielęgnacji i czyszczenia surowego drewna

- Use only mattress with thickness is 8-16 cm height
- Prohibit horseplay on or under bed(s)
- Do not hang on construction components
- The maximum load of the structure is 100 kg

Wooden and plastic should be cleaned with a dry cloth and ordinary, mild care and cleaning of raw wood